

umlora

Design by
Dechem Studio

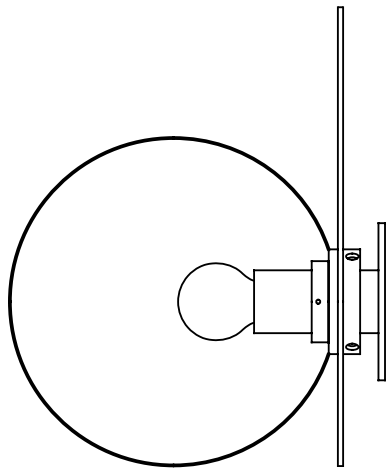

bomma

bomma.cz

TECHNICAL SHEET

UMBRA

wall & ceiling lighting

Design by
Dechem Studio

All Bomma products are hand-made from mouth-blown lead-free crystal. Therefore any small bubbles, non-melts and irregularities in the glass are both proof and a characteristic feature of this traditional craft.

The Umbra Collection is made by underlying colored glass technology. Thanks to the manual process of blowing underlay glass, each piece is an original. Individual products may vary slightly in intensity, hue or even color. This is an accompanying characteristic of the traditional underlay glass technology.

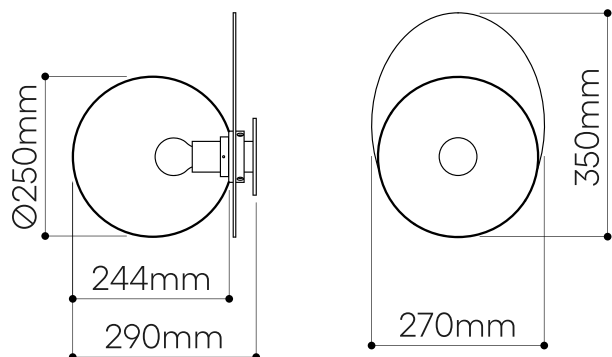

LIGHTING DESCRIPTION

Size	350 × 270 × 290 mm 13,8 × 10,6 × 11,4 inch
Cable	black textile braid 2,5 m / 98,4 inch
Weight	4,5 kg / 9,9 lb
Material	mouth-blown lead-free crystal in smoke grey, pink, clear and light grey
Mounting Materials	polished stainless steel with nitride titan coating
Mounting Colors	gold
Protection	IP 20
Nominal voltage	220-230V / A.C. 50 hz (EU) 100-120 V / A.C. 60 Hz (USA)
Class	I. EU / I. USA

LIGHT SOURCE

Type	G45, 3W LED, 290 lm
Base	E27 (EU) / E26 (USA)
Voltage	200-240V, AC 100-140V, AC
Temperature	2700 K
Color index	RA 90+
Dimming	Dimmable with TRIAC ; on demand dimmable with DALI, RF/WIFI, for information on dimming with other systems please contact your Bomma partner.

TRANSFORMER

Primary	100-240V, 50/60 Hz, 0,04A
Secondary	DC 700mA (0,5V-4V) 1x3W

PACKAGING

Material	Cardboard
Size	370 × 370 × 495 mm 14,6 × 14,6 × 19,5 inch

Origin: traditionally produced in the Czech Republic
Intellectual property license holder: Bomma Czech Republic (EU)
represented by Bohemia Machine s.r.o.

CERTIFICATES

